



## THE USE OF GNSS TO MONITOR THE DEFLECTIONS OF SUSPENSION BRIDGES

Gethin Wyn ROBERTS<sup>1</sup>, Chris BROWN<sup>2</sup>, Chris ATKINS<sup>1</sup>, Xiaolin MENG<sup>1</sup>

<sup>1</sup> IESSG, The University of Nottingham, UK

<sup>2</sup> School of Engineering and Design, Brunel University of West London, Uxbridge, UK

**Abstract:** The use of GPS for monitoring the deflections of large suspension bridges in the UK has been under research at the University of Nottingham and Brunel University for over a decade. The following paper details the main outputs from this work, focusing on the ability of GPS to measure the deflections to the order of a few millimetres, as well as measuring the fundamental frequencies of the bridges.

### 1. INTRODUCTION

The following paper details the ongoing research in deflection monitoring and deformation monitoring of structures, notably bridges. The use of kinematic GPS is being used for this and the work has been ongoing for about a decade at the University of Nottingham in collaboration with Brunel University [Ashkenazi *et al*, 1996], [Ashkenazi *et al*, 1997], [Brown *et al*, 1999]. It is possible to measure 3D deformations of discrete points upon the bridge at rates of up to 100Hz using GPS alone. It is also possible to measure sub-centimetre precisions over the short baselines used for this work. Typically the baseline lengths from the reference to rover receivers are approximately 1km or so.

Initial trials were carried out on the Humber Bridge and since then a number of trials have been carried out on other bridges including the Wilford Suspension Bridge in Nottingham, the Millennium Bridge in London and more recently the Forth Road Bridge in Scotland. During the trials, survey grade dual frequency GPS receivers are used, however, more recently research has also been carried out investigating the use of single frequency survey grade receivers (code and carrier) [Roberts *et al*, 2004], [Cosser *et al*, 2003]. Further to this, trials have been carried out investigating the use of cheap hand held GPS receivers as it is now possible to output the carrier phase from these receivers [Cosser *et al*, 2004].

The work itself investigates the use of kinematic GPS as well as comparing this to the modelling of such structures. The overall aim is to be able to use a fixed number of GPS receivers located upon the bridge at pre-determined discrete locations and comparing the movements at these points with the FEM. Once agreement between the real data and the FEM established, then it is then possible to use the FEM to model how the remainder of the bridge moves based upon this real data.

## 2. CASE STUDY 1; THE WILFORD SUSPENSION BRIDGE

The Wilford Suspension Bridge is located approximately 4km from the University of Nottingham's Campus and is held by two sets of suspension cables restrained by two massive masonry anchorages. The bridge has a span of 68m in length and 3.65m in width. It consists of a steel deck covered by a floor of wooden slats. Underneath the deck there are three gas and one water pipe laid underneath the deck transferring the utilities across the River Trent. It is possible to obtain several centimetres of movement under normal loading and this has been used by the IESSG since 2000. There are no long suspension bridges in close proximity to Nottingham, therefore this bridge is ideal for carrying out preliminary trials before trying the techniques out on longer bridges. Various trials have been carried out on the bridge. Details about these trial and the results can be found in [Cosser *et al*, 2003].

Figure 1 illustrates the deflection on two consecutive days and illustrates the multipath characteristics analysed through using the Adaptive Filtering (AF) technique developed at Nottingham. A spectral analysis of the resulting vertical movements is carried out, and under close inspection Figure 2 illustrates that the fundamental frequency of the deflection is 2.117 Hz. This compares very favourably with the accelerometer results of 2.116Hz.

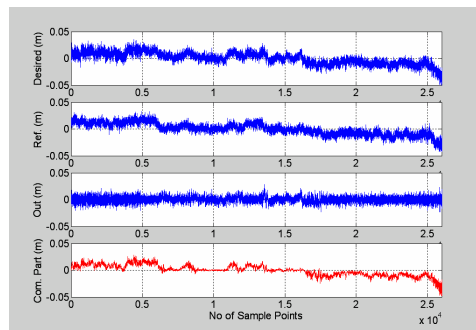

Figure 1 - Multipath Mitigation using AF on the Wilford Bridge. Two successive days' of GPS data compared.

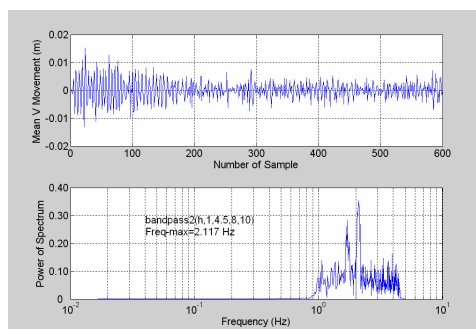

Figure 2 - Fundamental Frequency extracted from the GPS time series for the Wilford Bridge.

## 3. CASE STUDY 2; THE LONDON MILLENNIUM BRIDGE

The Millennium Bridge was designed by architect Sir Norman Foster, Sculptor Anthony Caro and Engineers Arup. The bridge was opened on the 10 June 2000, and closed on the 12 June

2000 following violent and un-predicted movements of the structure during a sponsored walk being carried out over it. The movement was rectified by placing dampers underneath the bridge. The bridge was closed for refurbishment and reopened on the 27 February 2002. The bridge has an overall length of 330m, width of 4m and lies at a height of 10.8 m above the River Thames at high tide. The bridge's piers are made of concrete and steel and the cables are 120mm lock coiled, with an aluminium decking. The construction cost for the bridge was approximately £18m and the modification costs were approximately £5m.

During its closure and before the refurbishment, the University of Nottingham and Brunel University were allowed to place GPS receivers upon the bridge to gather data to analyse the movement characteristics. Figure 3 illustrates the location of the antennas as well as the time of the antennas being placed at the survey points on the bridge. Due to the fact that the University of Nottingham only had four Leica SR530 dual frequency GPS receivers at the time, the reference station and the GPS receiver at point B were constantly in place. The other two GPS receivers were shared between points A, C, D and E as illustrated in Figure 3. These trials were carried out towards the end of November 2000.

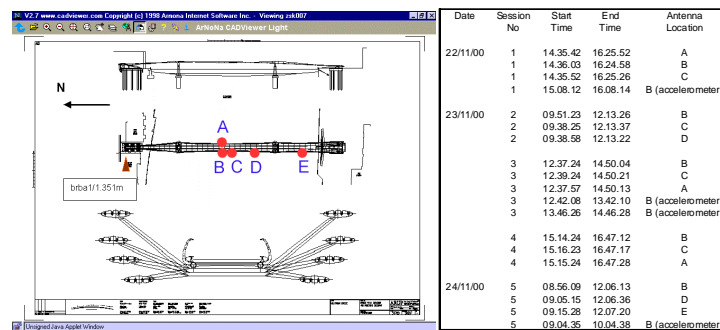

Figure 3 - Location and times of GPS occupation of the millennium Bridge.

Having processed the data an AF was used to mitigate the multipath, the results in Figure 4 were found showing the lateral dynamics at the midspan. The prediction for the natural frequencies at this point were found to be 0.5 and 0.95 Hz and the actual frequencies obtained by the GPS were 0.55Hz and 0.95Hz.

Figure 5 illustrates the lateral dynamics at the South Span. Again the prediction of the fundamental natural frequency is 0.77 Hz and the actual from GPS is 0.75Hz.

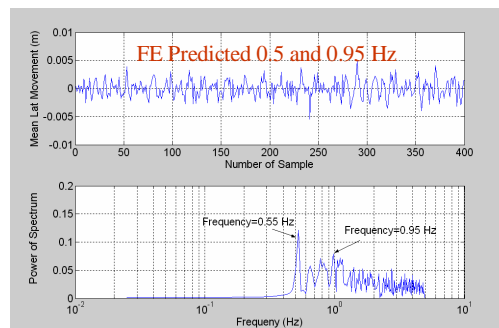

Figure 4 - Lateral Dynamics at mid span for the Millennium Bridge.

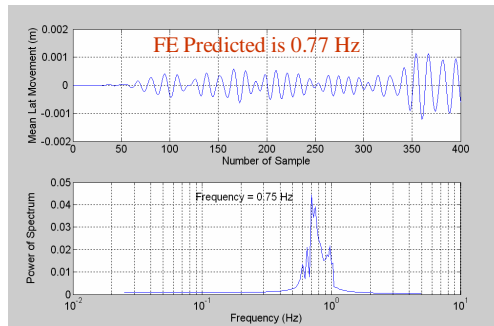

Figure 5 - Lateral Dynamics at South Span of the Millennium Bridge.

#### 4. CASE STUDY 3; THE HUMBER BRIDGE

A whole series of trials have been carried out on the Humber Bridge. Figure 6 illustrates the Humber Bridge with a midspan length of 1.4km, and an overall length of 2.22 km.



Figure 6 - The Humber Bridge showing a GPS receiver reference station in the foreground.

Extensive trials were carried out in March 2004, whereby 13 GPS receivers were used. Two receivers were located upon the Humber Bridge Control building, which is approximately at the same altitude as the bridge deck, one GPS receiver was placed at the estuary which is lower than the bridge and one receiver was placed at the top of the northern towers, which is approximately 155.5 m higher than the estuary.

Figure 7 illustrates the height deflections of points 1 and 7. It is clear from here that the two receivers located at opposite sides of the same part of the bridge experience similar movements. However, under closer inspection it can be seen that the difference in height between these two points does vary, illustrating that there is a torsional movement.

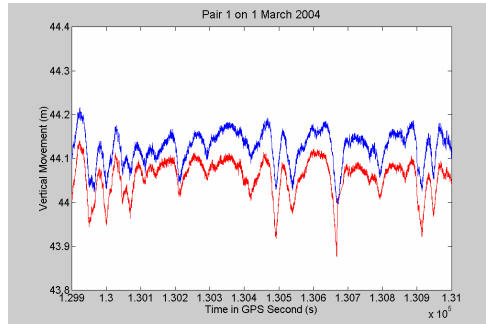

Figure 7 - Height Deflections on the Humber Bridge.

Figure 8 illustrates the results from carrying out a spectral analysis on the GPS results. It can be seen that the results of this are 0.117 Hz. The first vertical vibration frequency predicted by an FEM created by Brunel University is 0.116Hz.

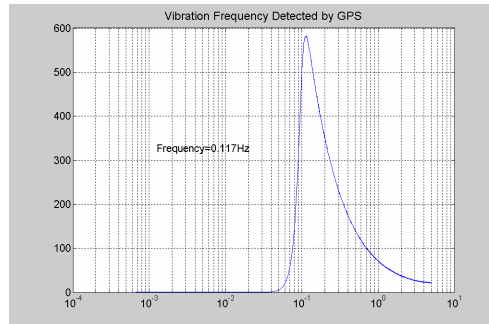

Figure 8 - Frequency analysis of the Humber Bridge data.

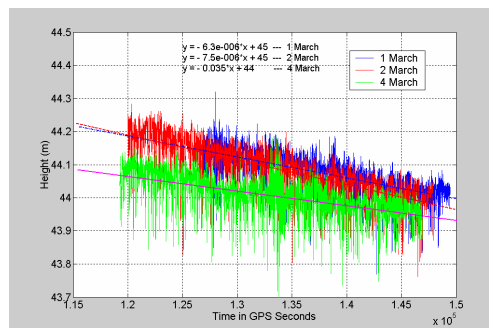

Figure 9 - Height deflections for the Humber Bridge.

Figure 9 illustrates the height of a point on the bridge on 3 consecutive days. On the third day the temperature was warmer, and it can be seen that the overall height of the bridge deck is lower. On all days the height gradually drops over a period of hours. This is due to the heating effect causing the steel cables to expand.

## 5. CASE STUDY 4; THE FORTH ROAD BRIDGE

The data gathering trials were conducted over a nearly continuous 46 hour period from 11am on the 8 February 2005 to 9am on the 10 February 2005. For the whole period, 7 GPS receivers were located upon the bridge, as illustrated in Figure 10, and two reference GPS receivers were located on the viewing platform adjacent to the FETA building, Figure 11. The GPS receivers gathered data at a rate of 10Hz. In addition, an Aplanix INS was located adjacent to point E [Hide *et al*, 2005]. The layout of the GPS antennas meant that a GPS antenna was located at each of the east side mid span, 1/4 span, 3/4 span and 3/8 span as well as the west side mid span and on top of the two southern towers. A selection of Leica SR530, SR510 and GX1230 surveying GPS receivers were used in conjunction with lightweight and choke ring GPS antennas.

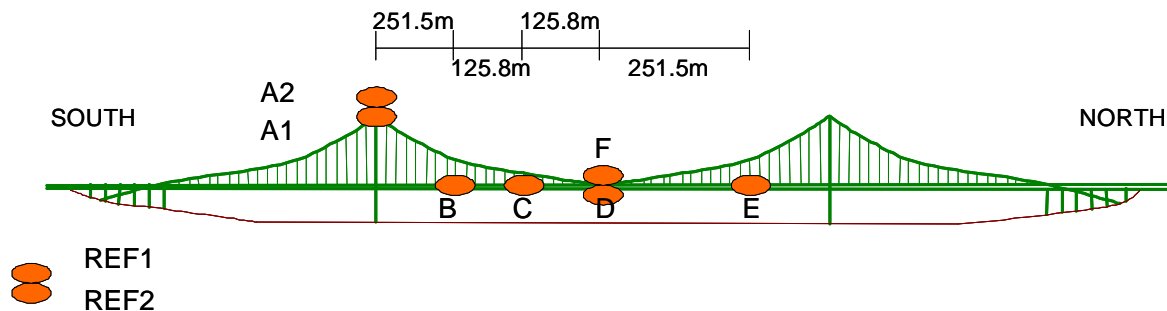

Figure 10 - Schematic of the Forth road bridge, and GPS receivers.



Figure 11 - Two GPS reference receivers located adjacent to the Forth road bridge (left). A GPS choke ring antenna attached to the bridge (right).

During the second night, two 40 tonne lorries were hired by FETA, accurately weighed and used as a control loading of the bridge. These trials were carried out a couple of hours after the high winds experienced subsided slightly, and during these specific trials the bridge was closed off to other traffic. The trials were carried out in the early hours of the morning, when the traffic flow over was at a minimum, and only closed whilst the control lorries passed over the bridge and re-opened whilst they turned around before subsequent crossings. The lorries started the trials at the North end of the bridge, and the manoeuvres were as follows.

- 1 lorry ran from North to South

- 1 lorry ran from South to midspan on west side, stopped then the other lorry moved north to south
- 1 lorry moved from north to south and stopped at midspan, other moved south to north
- 1 lorry moved from south to north, and then both moved side by side north to south

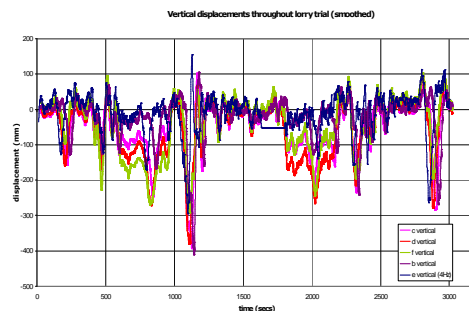

Figure 12 - Height Deflections of the Bridge During the lorry trials.

During these trials, the lorries travelled at 20 mph. Figure 12 illustrates the overall movements experienced by the bridge in the height component for the whole trials. The results show that the bridge deflected by up to 400mm due to the combined 80tonne loading

Figure 13 illustrates the final manoeuvre whereby the two lorries travelled from North to South whilst located side by side at 20mph. The graph also shows the physical location of the lorries at any time e.g. Midspan, North Tower etc

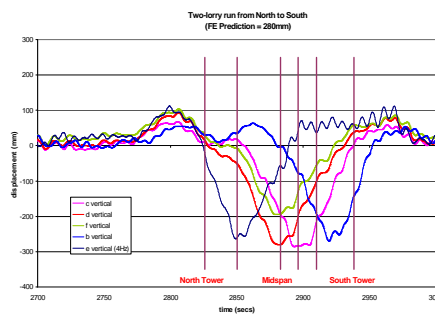

Figure 13 - Height deflections during the two 40tonne lorries passing over the Bridge side by side.

Three main phenomena are evident in Figure 13. Firstly the deflections are offset from each other. Secondly, the GPS receivers located at sites D and F, midspan, deflect by different magnitudes, even though they start off at the same height. This is due to the torsional movement of the bridge. The lorries, travelling on the left hand side of the carriageway from North to South, were in fact travelling on the East side of the bridge. Hence the eastern side (site D) deflects more than the Western side (site F). Thirdly, the reader should note that the bridge consists of three separate spans, each connected through a cable which passes over the top of the towers. As the lorries pass over the Northern side span, the load pushes this smaller span down, which in turn pulls the hanger cables down and the suspension cable which they are attached to. This then results in the suspension cable pulling up on the main span. This is



evident in Figure 13 at around 2,800s. The lorries pass into the main span, and their passage over the measured positions are shown in Figure 13. As the lorries pass into the southerly side span, upward movement of the main span – described above – is observed

## 6. CONCLUSION

The trials have shown that it is indeed feasible to use GPS on such structures to measure the magnitude and frequencies of the bridge's deflections in 3-D. This is possible at a rate of up to 10Hz, and all the results are synchronised to each other. Although the trials were carried out in a post processing manner, it is possible to have carried out these trials in real time.

The results have been compared to a FEM of the bridges, and this could well be the basis of future bridge monitoring whereby real GPS data from specific points on a bridge are used in conjunction with FEM, or similar model, to assess the behaviour of a bridge. If the structure deteriorates over time or if any specific mishaps occur then these actions may well be picked up through the model and GPS data.

### Acknowledgements

The authors wish to acknowledge the Forth Estuary Transport Authority, Humber Bridge Board and Arups for allowing access to the bridges, as well as their invaluable assistance. In addition, Fairhursts are acknowledged for their valuable assistance with the FEM of the Forth road bridge.

### References

- Ashkenazi, V., Dodson, A. H., Moore, T., and G. W. Roberts (1996) Real Time OTF GPS Monitoring of the Humber Bridge, *Surveying World*, May/June 1996, Vol. 4, Issue 4, ISSN 0927-7900, pp 26-28.
- Ashkenazi V. and G. W. Roberts (1997) Experimental Monitoring the Humber Bridge with GPS. In: *Proc. Institution of Civil Engineers; Civil Engineering*, Nov 1997, vol 120, Issue 4., pp. 177-182. ISSN 0965 089 X.
- Brown, C. J., Karuna, R., Ashkenazi, V., Roberts, G. W. and R. Evans (1999) Monitoring of Structures using GPS, In: *Proc Institution of Civil Engineers, Structures*, February 1999, pp 97 - 105, ISSN 0965 092X.
- Roberts, G. W., Meng, X., Cosser, E. and A. H. Dodson (2004) The Use of Single Frequency GPS to Measure the Deformations and Deflections of Structures. In: *Proc of the FIG Working Week*, May 2004, Athens.
- Cosser, E., Roberts, G. W., Meng, X., and A. H. Dodson (2003) The Comparison of Single Frequency and Dual Frequency GPS for Bridge Deflection and Vibration Monitoring. In: *Proc of the Deformation Measurements and Analysis, 11th International Symposium on Deformation Measurements*, International Federation of Surveyors (FIG), May 2003, Commission 6 - Engineering Surveys, Working Group 6.1, Santorini, Greece.
- Cosser, E., Hill, C.J., Roberts, G. W., Meng, X., Moore, T. and A. H. Dodson (2004) Bridge Monitoring with Garmin Handheld Receivers. In: *Proc of the 1st FIG International Symposium on Engineering Surveys for Construction Works and Structural Engineering*, June 2004, Nottingham, UK.





**13th FIG** Symposium on Deformation Measurement and Analysis

**4th IAG** Symposium on Geodesy for Geotechnical and Structural Engineering

LNEC, LISBON 2008 May 12-15

---

Hide, C; Blake, S; Meng, X; Roberts, G W; Moore, T; Park, D; (2005) An Investigation in the use of GPS and INS Sensors for Structural Health Monitoring, Proc ION GNSS 2005, 13-16 September, 2005, Long Beach, California

**Corresponding author contacts**

Dr Gethin ROBERTS

gethin.roberts@nottingham.ac.uk

The University of Nottingham

UK